

# BMT-AI8

## BACnet MS/TP Analog Input Module



- 2선식 BACnet MS/TP 포트 1개
- 통신 속도: 9600, 19200, 38400, 57600, 76800, 115200 Baud Rate
- 네트워크 주소: 00~F9 (0~249)
- LED: 동작 상태 및 에러 표시
- 동작 전원: 24V AC/DC
- IP40 보호 규격
- 35mm 단레일 장착
- 동작 온도: -5 ~ +55°C



프로토콜	BACnet MS/TP
Address 범위	00 ~ F9
인터페이스	RS485 (two-wire bus)
Baud Rate	9600 to 115200 bit/s
소비 전압	24 V AC/DC $\pm$ 10% (SELV)
소비 전력	65 mA (AC) / 25 mA (DC)
Relative duty cycle	100%
입력	8 X Analog Input, 0V ~ 10V DC
Input / voltage	30 V AC/DC
Input / high signal	more than 7V AC/DC
Display	Green, Red and Yellow LED
동작 환경 / 동작 온도	IP40, -20°C ~ +70°C
크기/무게	50(W) x 60(D) x 69.3(H) mm / 104 g
인증	KC, CE, FCC, UL, BTL

# Wiring Diagram

## Wiring Diagram

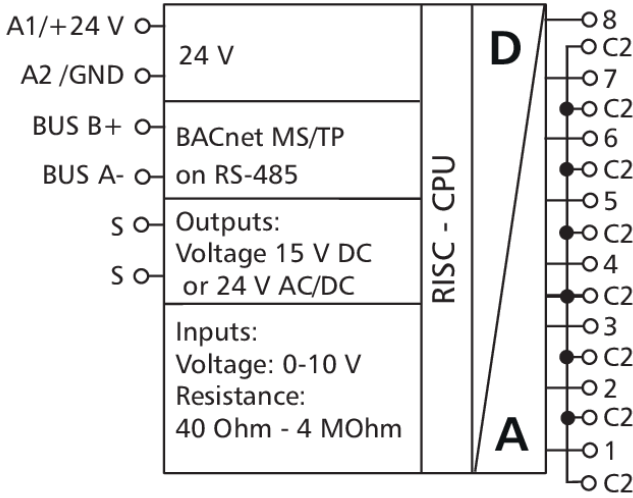

A2 = C2 = GND

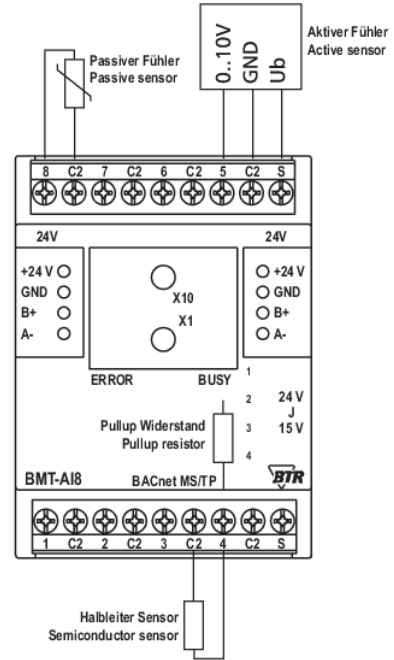

## Connection Example

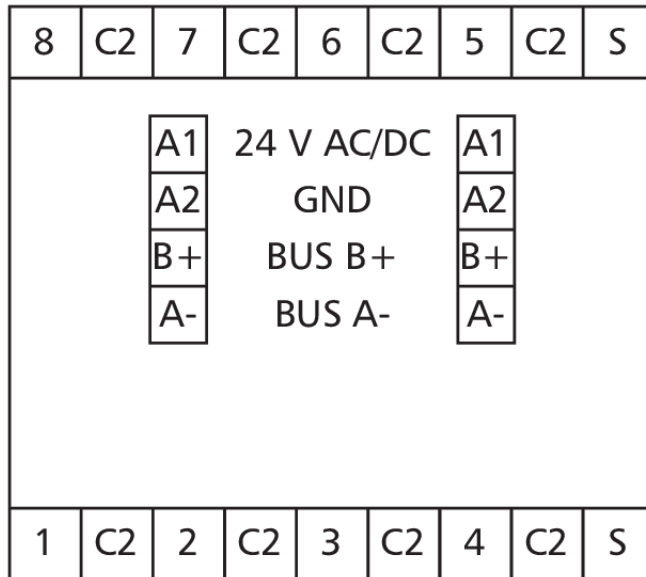

# Dimensions

## Dimensions

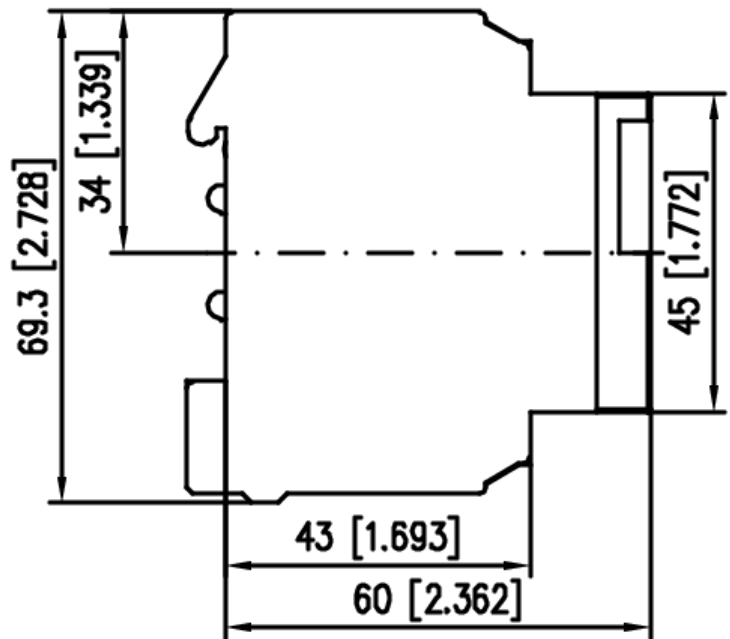
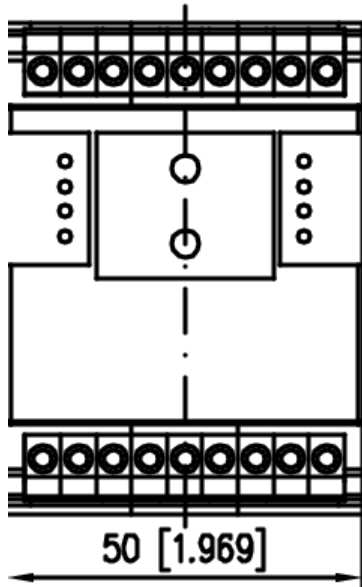

**(W)50 mm x (D)60 mm x (H)69.3 mm**